

• AL30+

0°C to 1000°C

Features

- Wide temperature ranges from 0°C to 1000°C
- Focusable Optics
- Response Time 60msec.
- Spectral range 8 μm....14 μm
- Integrated OLED Display & Parameterizing Keys
- Laser targeting
- Analog output options 0...20mA, 4...20mA
- RS-485 Serial interface
- User friendly PC software for communication
- Green LED for pyrometer status indication
- Red LED for Laser ON/OFF indication

Standard Scope of Supply

- Pyrometer with Focusable optics, OLED Display & Parameterizing Keys
- Laser pilot light(PL)
- Analog output 4...20mA, 0...20mA
- Digital Interface RS-485
- 5 mtr long connection cable with connector
- Calibration certificate, Software & Operation manual

Optional

- Mechanical & Electrical Accessories
- Extra Cable Lengths

Applications

- Plastic
- Fluid
- Rubber
- Ceramic
- Wood
- Glass
- Coated Metals
- Textiles

• AL30+

On-line Single Color Infrared Focusable Non-contact Pyrometers
For Non-Metallic Applications



AL30+ is a highly accurate digital single color IR Focusable pyrometer with thermopile sensor provides the advantages of non contact temperature measurement of non-metallic surfaces, Painted, coated or anodized metals etc.

The IR pyrometer parameters can be selected via the key pads on the back panel. The settings are displayed on the OLED Display. In the measuring mode real time temperature is displayed.

AL30+ have focusable optics for optimal match of the instrument for various applications. The pyrometers are equipped with RS-485; analog outputs 0/4....20. Switching laser ON/OFF does not effect the measurement.

Software “Infrasoft”

AST “Infrasoft” software is under standard scope of supply. It offers possibilities of connecting three pyrometers simultaneously for parameter setting, view real time graph, offline graph and to evaluate measuring data. Communication between the pyrometer and the software is implemented via a cable connected between the pyrometer and the PC serial port. It comes with spot size calculator and parameter settings features.

Below parameters are adjustable via software

- Emissivity, Response Time
- Clear Time (Peak Picker)
- Analog Output
- Sub Range
- Unit of Temperature (°C/°F)

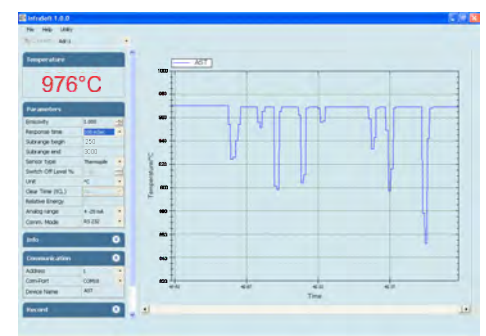

Technical Specifications

Model	AST AL30+
Temperature Range (Analog sub-range adjustable)	0°C - 1000°C
Spectral Range	8 μm ... 14 μm
Photodetector Type	Thermopile
Distance to Spot Size Ratio	130:1
Emissivity (ε)	0.1....1.0 adjustable
Response Time	60 msec adjustable upto 10 sec
Accuracy	± 1% of the measured value or + 2°C
Repeatability	0.3% of reading in °C + 1°C
Sighting Options	Laser Pilot Light(PL)
Analog Output	0-20mA, 4-20mA (User selectable)
Digital Output	RS-485
Operating Temp. Range	0°C.....70°C
Storage Temp. Range	-20°C...70°C
Adjustable Parameters and Features via Software and Android app	Emissivity, Response Time, Clear Time (Peak Picker), Analog Output, Analog Scale (Sub range), Unit Of Temperature(°C/°F), Communication mode (Comm. mode), Relay set point & hysteresis, etc.
Adjustable Parameters and Features via Keypad	Emissivity, Response Time, Clear Time (Peak Picker), Analog Output, Analog Scale (Sub range), Unit Of Temperature(°C/°F), Communication mode (Comm. mode), Relay set point & hysteresis, address, etc.
Relay output	One Relay output with hysteresis 60V DC / 42 AC RMS, 0.4 A
Power Supply	12V to 28V DC with reverse voltage protection
Power Consumption	Max 4.0 watt
Laser Power	<1 m watt
Protection Class	IP65
Housing	Stainless Steel
Isolation	Power supply, Digital output and Analog output are galvanically isolated against each other
Operating Humidity	10-95%, Non-Condensing Conditions
Weight & Dimensions	1200g Dia= Ø 56mm; Length=188.5mm

Spot Sizes

Spot Sizes(mm)		
Focused working distances WD (mm)	Length (mm)	AL30+ (130:1)
500	13.50	3.8
700	9.20	5.4
1000	5.60	7.7
2000	2.00	15.4
5000	0.00	39.0

We measure accurate temperature in extreme conditions

Pyrometer & Cooling Jacket Drawing

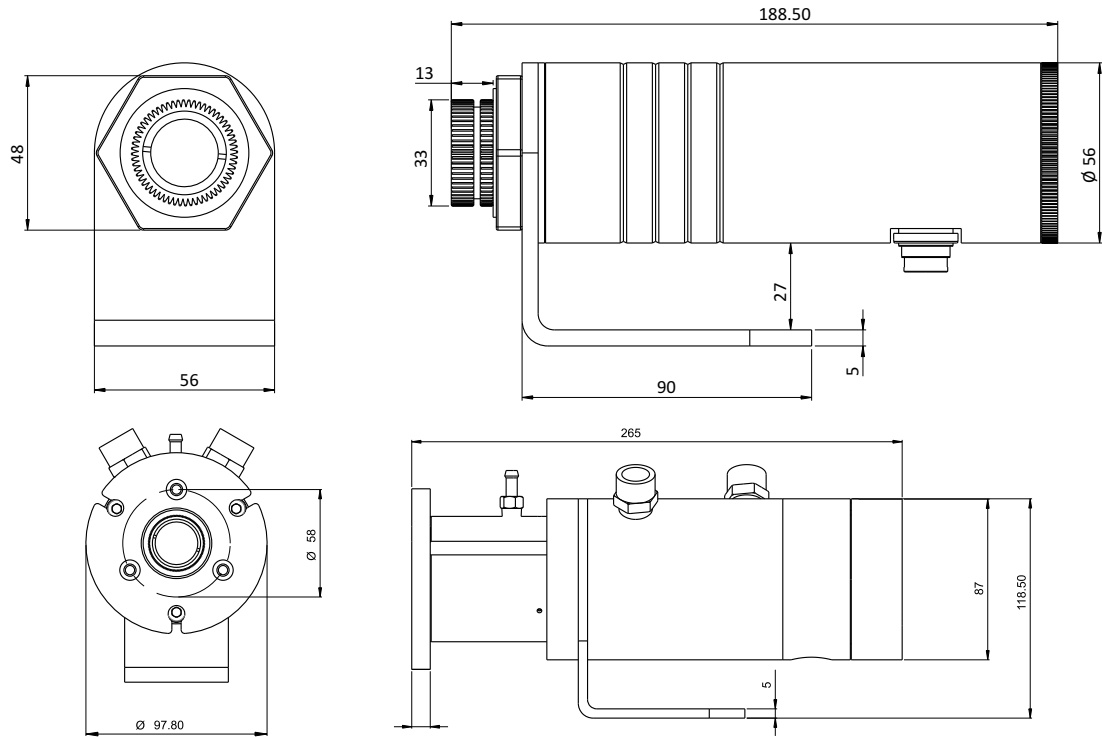

Accessories

Mounting Clamp (Pyrometer)
(Reference no: 8500-04)



Air Purge
(Reference no: 8500-05)



Mounting Clamp (Water Cooling Jacket)
(Reference no: 8500-06)



Mounting Flange
(Reference no: 8500-07)



Mounting Plate
(Reference no: 8500-08)



Water Cooling Jacket
(Reference no: 8500-09)



Temperature Indicator
(Reference no: 9000-01)



Adjustable Mounting Stand
(Reference no: 8000-07)

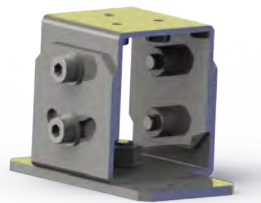

Power supply Input 110/230V AC
(Reference No. 9000 - 02)
Output 24 V DC, 0.7Amp.



We measure accurate temperature in extreme conditions

Assembly Options

Pyrometer with Mounting Clamp (8500-04)

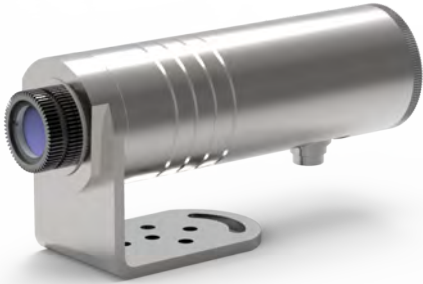

Pyrometer with Mounting Flange (8500-07) + Air Purge (8500-05) + Water Cooling Jacket (8500-09)



Pyrometer with Air Purge (8500-05) + Mounting Clamp (8500-06)

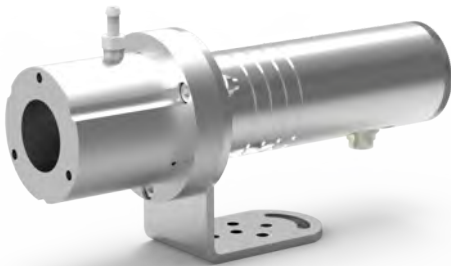

Pyrometer with Water Cooling Jacket (8500-09) + Mounting Clamp (8500-06)



Pyrometer with Mounting Flange (8500-07) + Air Purge (8500-05)

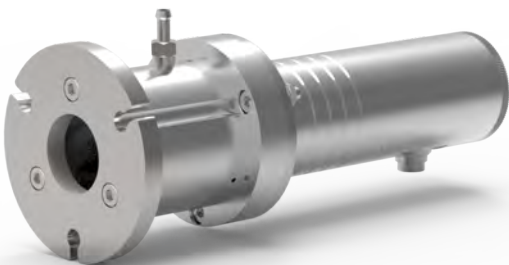

Pyrometer with Mounting Flange (8500-07) + Air Purge (8500-05) + Water Cooling Jacket (8500-09)

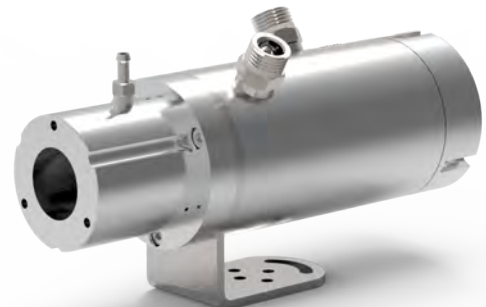

Accurate Sensors Technologies Pvt. Ltd.
Misgav Industrial Park, Misgav 20174 Israel
Phone :+972-4-9990025, **Fax** : +972-4-9990031
E-mail : info@accuratesensors.com

Accurate Sensing Technologies Pvt. Ltd.
188A, B-169 (Part), B-188 (A), Road No. - 5, M. I. A.,
Madri, Udaipur (Rajasthan) - 313003
Phone : +91-294-3507736, **Fax** : +91-294-3507731
Email : sales@accuratesensors.com

AST 
Accurate Sensors Technologies